

带座外球面球轴承

UCP2立式带座外球面向心球轴承组件 带止动螺钉-UC210-200D1+UCP210-200D1+P210D1

参数信息:

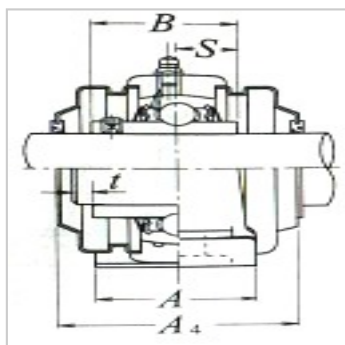
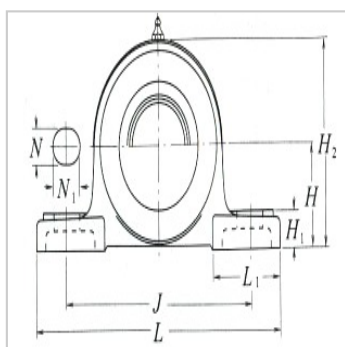
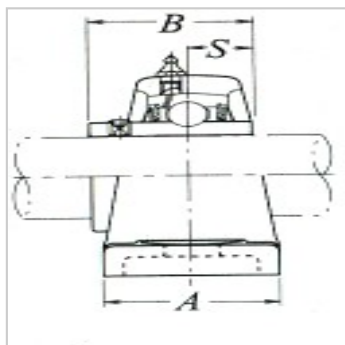
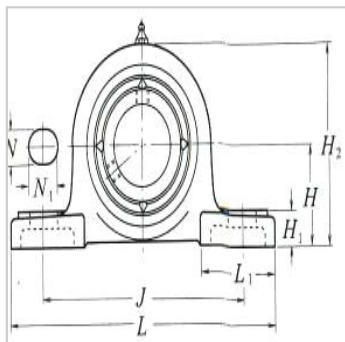

轴径inch :	2
座组件轴承型号(1) :	UCP210-200 D1
尺寸inch :	
H :	2 1/4
L :	8 1/8
J :	6 1/4
A :	2 3/8
N :	25/32
N :	29/32
H :	13/16
H :	4 1/2
L :	2 9/16
B :	2.0315
S :	0.748
安装螺栓规格inch :	5/8
轴承代号 :	UC210-20 0D1
座外型号 :	P210D1
带钢板外罩座组件轴 承型号 :	-
带铸铁外罩座组件轴 承型号 :	-
尺寸inch :	
t(最大) :	
A :	
H :	
A :	
带座轴承重量lb :	
UCP :	
Z(ZM) :	

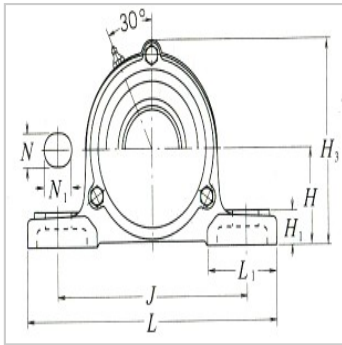

C(CM) :

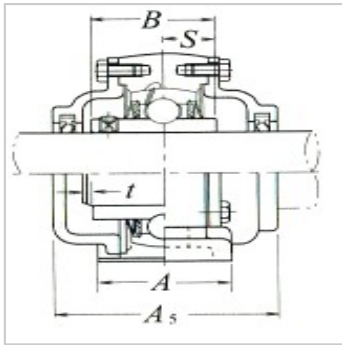

: